



Series 466 Awning / Casement Window



DESIGN FEATURES

- This 102mm thick commercial grade awning window has been designed with bold frame lines and thick (strong) sashes that can carry heavy glass including 24mm thick double glazing.
- The perimeter frame has been designed to make installation into brick veneer and cavity brick easier with built-in nailing fins (weather bars). The sub-sill that comes with this window also has a built-in nailing fin.
- This high performance awning and casement window system has been designed around custom frame and sash extrusions.
- The extra strong sashes allow large sash windows to be fabricated for high wind load areas.
- Splayed or square glazing beads available.
- Awning sashes can be fitted with cam handles, manual chain winders or concealed electric winders. The winder options suit fixed fly screen installation.
- Our heavy duty chain winder comes standard with non corrosion Polesium™ base and stainless steel chain.
- Fixed lowlights/sidelights can be single or double glazed.
- Sashes are hung on heavy duty four bar stainless steel or aluminium stays.
- Sashes will accept a variety of glass thicknesses from 4mm single panes to 24mm insulating glass units.
- Two non-facing (recessed) sash designs cover internal and external glazing.
- The nailing fin frames are suitable for brick veneer and cavity brick wall installations. Two jamb sizes 30mm standard or alternative 44mm wide.

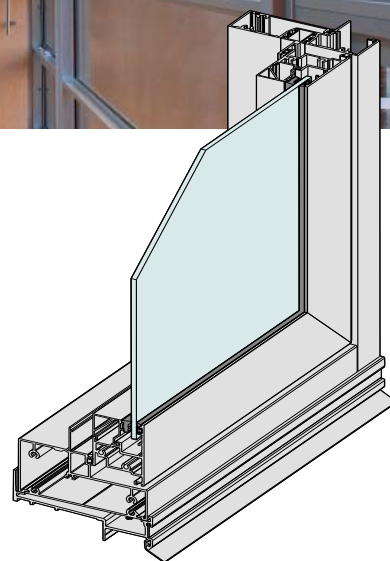

Maximum Panel Height	1800mm
Maximum Panel Width	1210mm
Maximum Glass Thickness	≤ 24mm

Subject to individual site conditions. Contact AWS Technical Support for more information.



WERS RATED PRODUCT



ENHANCED ACOUSTIC PERFORMANCE



3D & 2D CAD FILES AVAILABLE



PRODUCT INFORMATION AVAILABLE AT WWW.AWSCOMMERCIAL.COM.AU



SPECIFIER ASSISTANCE AVAILABLE

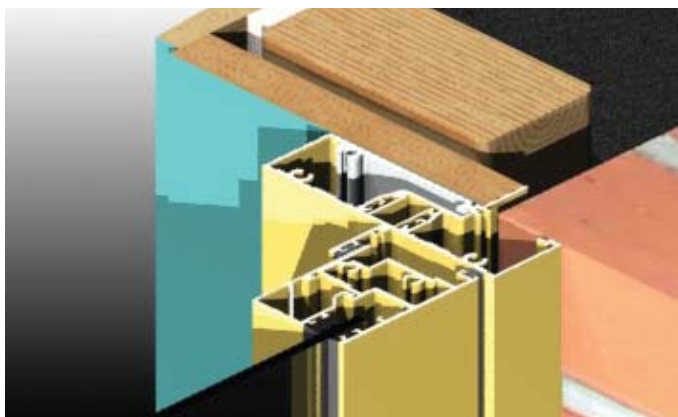

A major feature with Series 466 is the frame with in-built nailing fin (weather bar). This makes installation into cavity brick with height adjustable building-in lugs and into brick veneer walls with timber reveals as shown above possible. The standard jamb is 102 x 30mm as shown above, we also offer 102 x 44mm jamb and again with the nailing fin feature. Nailing fins may not sound that important but this built-in weather bar is what stops water traveling from the outer brick skin to the inner wall. The sashes are 40mm thick, recessed into the frame as illustrated and can be beaded/glazed from the inside as shown or alternatively from the outside. We can use square or splayed beads if glazed on the outside.

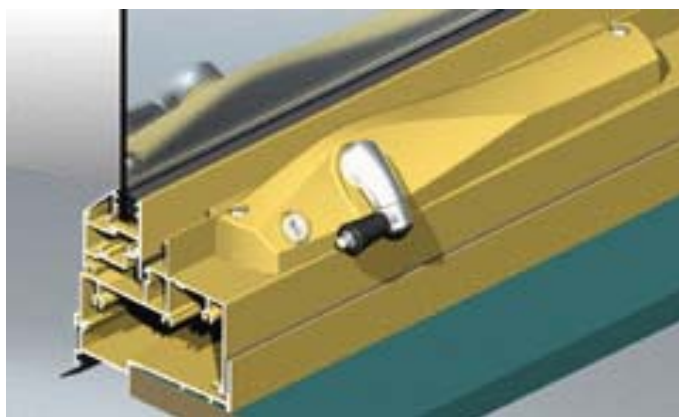

The standard chain winder used on Series 466 comes standard with stainless steel chain and Polesium™ cover and base. These corrosion resisting features make the winder suitable for exposed locations. 10 Year manufacturers warranty. We also fix the winder to the frame and sash through thickened area.

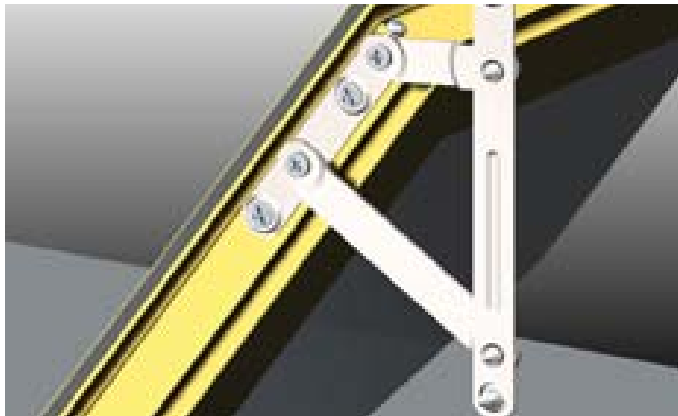

Series 466 sashes are hung on heavy duty four bar stays – aluminium or stainless steel.

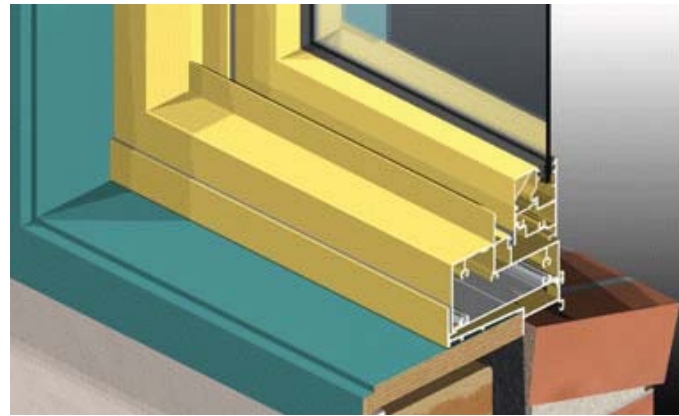

Sub-sills are standard on Series 466. The sub-sill has several significant features:

- Full flashing tray guides any water that gets into the window back to the outside.
- Our custom sub-sill designed for cavity brick and brick veneer construction has built-in nailing fin to allow sill timber reveal fixing.
- The PVC flap on the outer edge of the sub-sill caters for stud wall settlement on brick veneer construction.
- Sub-sill fitted with co-extruded Santoprene drain hole cover flap to prevent blow back under extreme situations.
- Sub-sill is also stop ended to guide water back to the front.



2D & 3D CAD FILES AVAILABLE
GO TO: www.awscommercial.com.au >
CAD & Revit 3D Files
CAD file: *DWG or DXF AWS_466_1*



MORE INFORMATION
For the latest updates regarding
this product visit our web site
www.awscommercial.com.au